

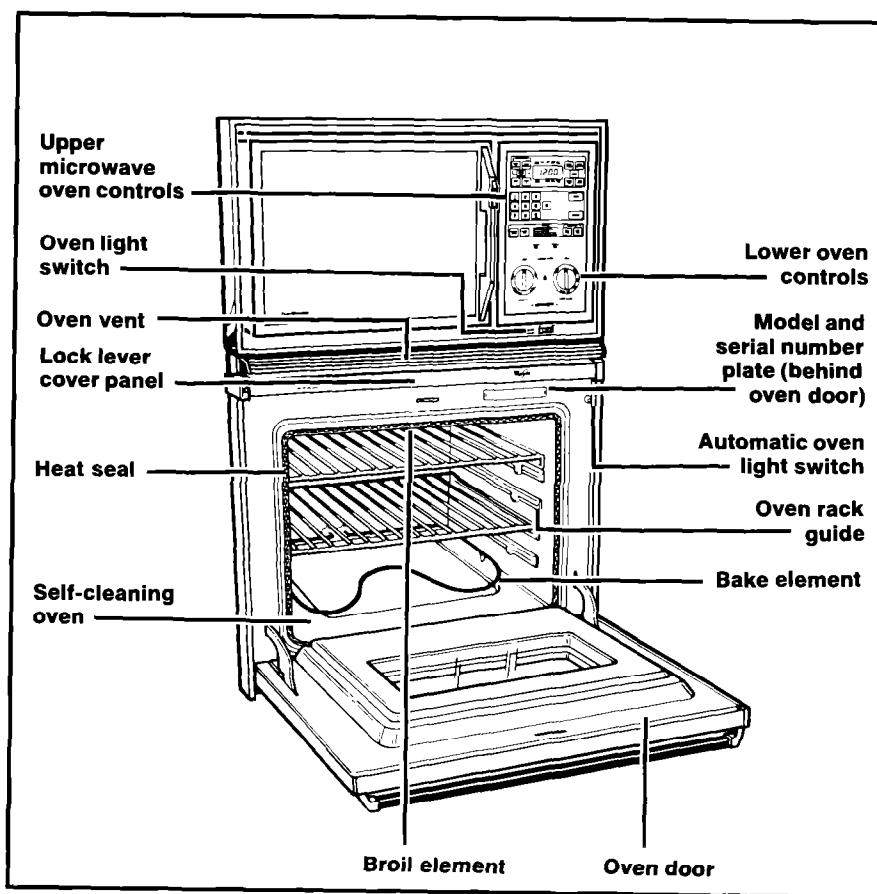

Use & Care Guide



**SELF-CLEANING LOWER OVEN
RM286PXV**

Contents

	Page
Important Safety Instructions	3
Using Your Lower Oven	5
Setting the clock	5
Using the Minute Timer	5
Using the lower oven controls ..	5
Using the automatic MEALTIMER* control	9
The oven vent	12
Optional rotisserie	12
Door panel replacement	12
Caring For Your Lower Oven ..	13
Control panel and knobs	13
Using the Self-Cleaning cycle ..	14
Cleaning tips	19
The lower oven light	20
If You Need Service Or Assistance	21
Whirlpool Microwave Oven/Range Product Warranty	24

*Tmk

©1989 Whirlpool Corporation

Remove the Consumer Buy Guide label. It will be easier to remove before the lower oven is used. To remove any remaining glue:

- Rub briskly with thumb to make a ball, then remove.
or
- Soak area with liquid hand dishwashing detergent before removing glue as described above.

Do not use rubbing alcohol or flammable or toxic solvents, such as acetone, gasoline, carbon tetrachloride, etc. These can damage the finish.

Thank you for buying a Whirlpool appliance. Please complete and mail the Owner Registration Card provided with this product. Then complete the form below. Have this information ready if you need service or call with a question.

- Copy model and serial numbers from plate (behind the microwave oven door on the frame) and purchase date from sales slip.
- Keep this book, the Upper Microwave Oven Use and Care Guide, the Cooking Guide and sales slip together in the Literature Pac.

Model Number

Serial Number

Purchase Date

Service Company Phone Number

You are responsible for:

- Installing and leveling the oven in a wall or cabinet strong enough to hold its weight, and where it is protected from the elements.*
- Properly connecting and grounding the oven to electrical supply.*
- Making sure the oven is not used by anyone unable to operate it properly.
- Properly maintaining the oven.
- Using the oven only for jobs expected of a home oven.

*See the Installation Instructions.

Important Safety Instructions

⚠ WARNING

To reduce the risk of fire, electrical shock, injury to persons, or damage when using the lower oven, follow basic precautions, including the following:

- Read all instructions before using the lower oven.
- Install or locate the oven only in accordance with the provided Installation Instructions.
- Do not use the lower oven for warming or heating the room. Persons could be burned or injured, or a fire could start.
- Do not leave children alone in area where the lower oven is in use. They should never be allowed to sit or stand on any part of the lower oven. They could be burned or injured.
- Do not repair or replace any part of the lower oven unless specifically recommended in this manual. All other servicing should be referred to a qualified technician.
- Do not store flammable materials in or near the lower oven. They could explode or burn.
- Do not use water on grease fires. Never pick up a flaming pan. Smother flaming pan by covering with a well-fitted lid, cookie sheet or flat tray. Flaming grease outside pan can be extinguished with baking soda, or if available, a multipurpose dry chemical or foam-type extinguisher.
- Use only dry potholders. Moist or damp potholders on hot surfaces may result in burns from steam. Do not let potholder touch hot heating elements. Do not use a towel or bulky cloth for a potholder. They could catch on fire.
- Use care when opening oven door. Let hot air or steam escape before removing or replacing food.
- Do not heat unopened containers. They could explode. The hot contents could cause burns and container particles could cause injury.
- Keep lower oven vents unobstructed.
- Always position oven racks in desired location while oven is cool. If rack must be moved while oven is hot, do not let potholder contact hot heating element in oven.
- Do not clean door seal. It is essential for a good seal. Care should be taken not to rub, damage, or move the seal. Clean only parts recommended in this Use and Care Guide.
- Do not use oven cleaners. No commercial oven cleaner or oven liner protective coating of any kind should be used in or around any part of the oven.

Important Safety Instructions Continued

- Before self-cleaning the lower oven, remove broiler pan, broiler grid, oven racks and other utensils. Do not use the oven to clean miscellaneous parts.
- Do not store things children might want above the oven. Children could be burned or injured while climbing on it.
- Do not touch heating elements or interior surfaces of oven. Heating elements may be hot even though they are dark in color. Areas near interior surfaces of an oven become hot enough to cause burns. During and after use, do not touch, or let clothing or other flam-

mable materials contact heating elements or interior surfaces of oven until they have had sufficient time to cool. Other surfaces of the lower oven may become hot enough to cause burns; such as, the oven vent opening, the surface near the vent opening, the oven door and window.

**• FOR YOUR SAFETY •
DO NOT STORE OR USE
GASOLINE OR OTHER
FLAMMABLE VAPORS AND
LIQUIDS IN THE VICINITY OF
THIS OR ANY OTHER
APPLIANCE. THE FUMES
CAN CREATE A FIRE
HAZARD OR EXPLOSION.**

– SAVE THESE INSTRUCTIONS –

Using Your Lower Oven

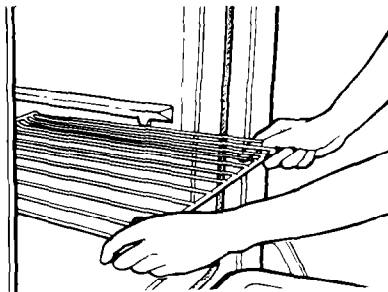
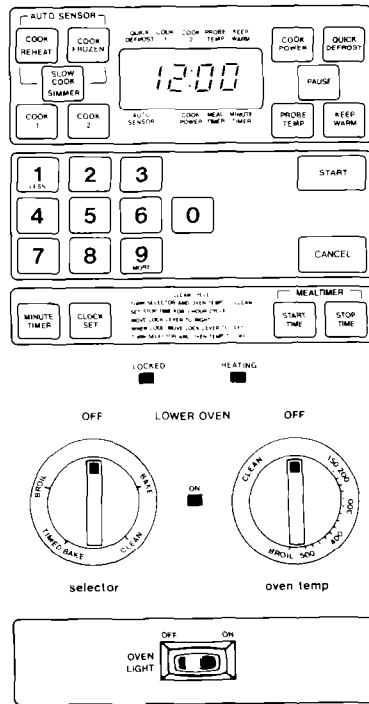

Setting the clock

The clock is located at the top of the upper microwave oven control panel. **To set the clock**, follow the instructions found in the Upper Microwave Oven Use and Care Guide.

Using the Minute Timer

The Minute Timer on the upper microwave oven control panel can be used for any timed cooking. **To use the Minute Timer**, follow the instructions found in the Upper Microwave Oven Use and Care Guide.

Using the lower oven controls

The lower oven is always set with two knobs:

- The Oven Selector
- The Oven Temperature Control

Both must be on a setting for the lower oven to heat.

Baking

1. Position the rack(s) properly **before** turning on the oven. **To change rack position**, lift rack at front and pull out.

The rack(s) should be placed so the top of the food will be centered in the oven. Always leave at least 1½ to 2 inches (4-5 cm) between the sides of the pan and the oven walls and other pans. For more information, see the Cooking Guide.

Using Your Lower Oven Continued

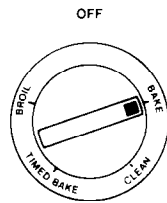

selector

2. Set the Oven Selector on BAKE.
The lower oven ON signal light will come on.

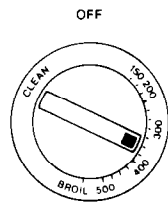

oven temp

3. Set the Oven Temperature Control on the baking temperature you want.
The lower oven HEATING signal light will come on. The oven is preheated when the lower oven HEATING signal light first goes off.

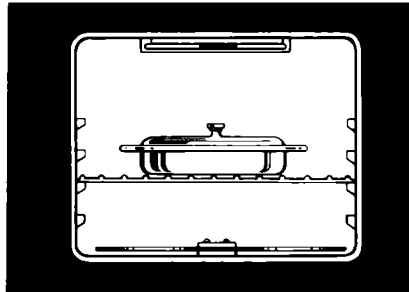

4. Put food in the oven.

During baking, the elements will turn on and off to keep the oven temperature at the setting. The lower oven HEATING signal light will turn on and off with the elements.

The top element helps heat during baking, but does not turn red.

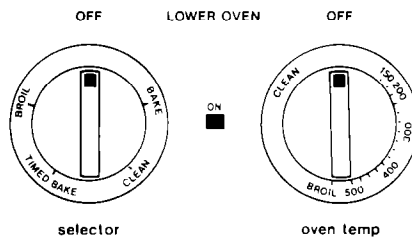

5. When baking is done, turn **both** the Oven Selector and Oven Temperature Control to OFF. The lower oven ON and HEATING signal lights will go off.

Adjusting the oven temperature control

Does your oven seem hotter or colder than your old oven? The temperature of your old oven may have shifted gradually without you noticing the change. Your new oven is properly adjusted to provide accurate temperatures. But when comparing to your old oven, the new design may give you different results.

If after using the oven for a period of time, you are not satisfied with the temperature settings, they can be adjusted by following these steps:

1. Pull the Oven Temperature Control Knob straight off.

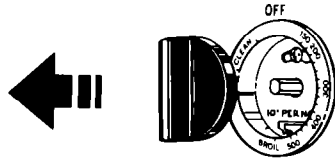

2. Loosen the locking screw. **Note the position of the notches.**

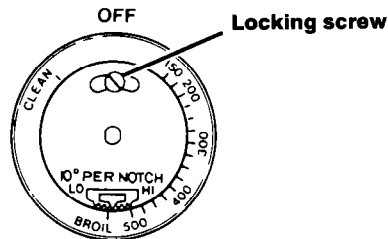

3. **To lower the temperature**, move a notch closer to LO. Each notch equals about 10°F (5°C).
4. **To raise the temperature**, move a notch closer to HI. Each notch equals about 10°F (5°C).

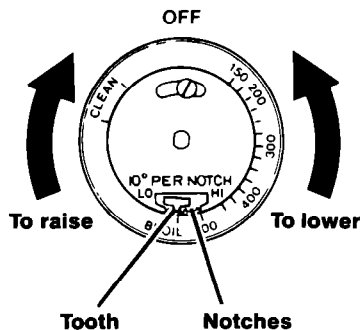

Tighten the locking screw and replace the control knob.

Using Your Lower Oven Continued

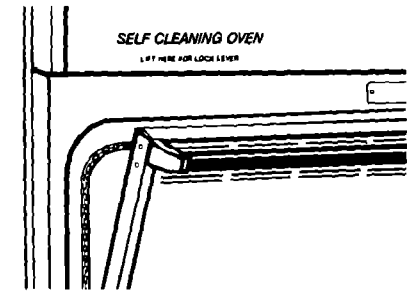
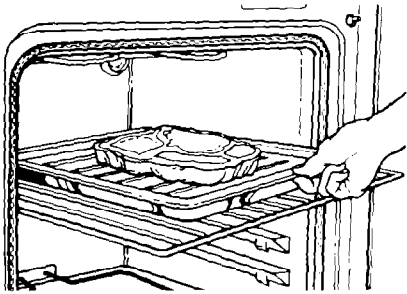
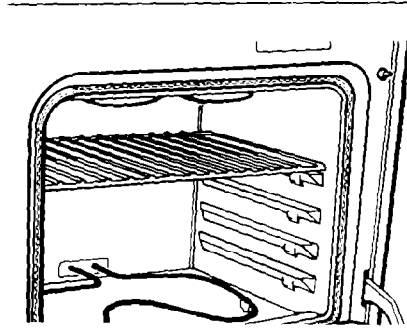

Broiling

1. Position the rack before turning the oven on. See "Broil Chart" in the Cooking Guide or a reliable cookbook for recommended rack positions.

2. Put the broiler pan and food on the rack.

3. Close the door to the Broil Stop position. (open about 4 inches, 10.2 cm). The door will stay open by itself.

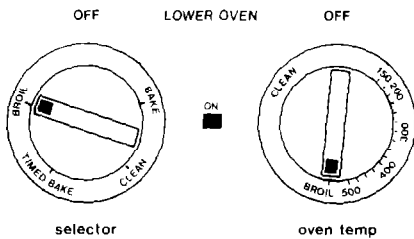

4. Set the Oven Selector and Oven Temperature Control on BROIL. The lower oven ON and HEATING signal lights will come on.

5. When broiling is done, turn **both** the Oven Selector and Oven Temperature Control to OFF. The lower oven ON and HEATING signal lights will go off.

Custom broil

- If food is cooking too fast, turn the Oven Temperature Control **counter-clockwise** until the lower oven HEATING signal light goes off.
- If you want food to broil slower from the start, set the Oven Temperature Control between 150°F and 325°F (65.5°C and 162.7°C). The lower the temperature, the slower the cooking.

The Oven Selector must be on BROIL for all broiling temperatures.

NOTE: The lower oven door must be partly open whenever the oven is set to BROIL. Leaving the door open allows the oven to maintain proper temperatures.

Using the automatic MEALTIMER* control

The automatic MEALTIMER* control will turn the lower oven on and off at times you set...even when you are not around.

Automatic baking is ideal for foods which do not require a preheated oven, such as meats and casseroles. **Do not use the automatic cycle for cakes, cookies, etc....undercooking will result.**

*Tmk

To delay start and stop automatically:

1. Position the rack(s) properly and place the food in the oven.
2. **Make sure the clock is set to the right time of day.** (See the Upper Microwave Oven Use and Care Guide for setting instructions.)

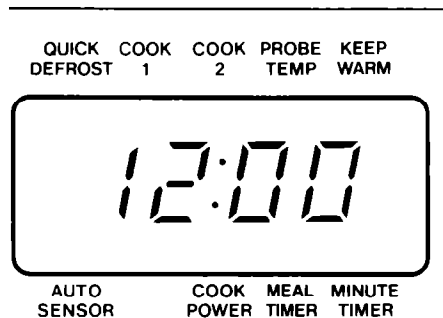

Using Your Lower Oven Continued

OFF

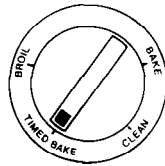

selector

3. Set the Oven Selector on TIMED BAKE.

OFF

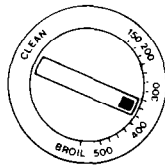

oven temp

4. Set the Oven Temperature Control on the baking temperature you want.

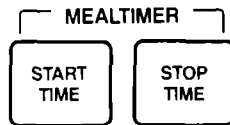

5. Touch the Start Time pad. Then touch the number pads for the time you want baking to start. (**Option:** Skip this step if you want to start baking immediately.)
6. Touch the Stop Time pad. Then touch the number pads for the time you want baking to stop.

START

7. Touch START. The oven will now start and stop automatically.

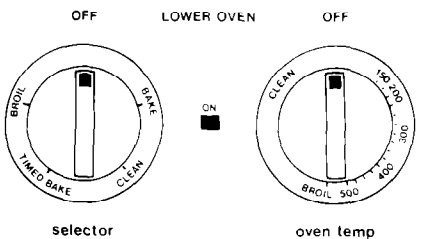
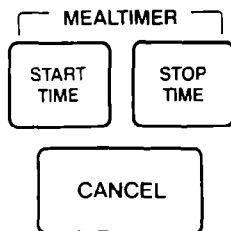
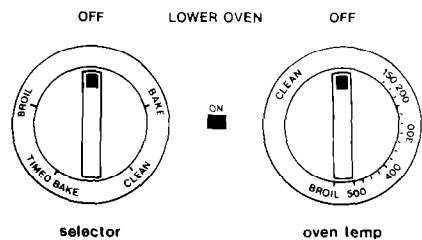

8. After baking is done or to stop the oven before preset time, turn both the Oven Selector and Oven Temperature Control to OFF.

To cancel the MEALTIMER* control settings:

1. Touch STOP TIME.
2. Touch CANCEL.

3. Turn the Oven Selector and Oven Temperature Control to OFF.

⚠ WARNING

To avoid sickness and food waste when using the MEALTIMER* control:

- Do not use foods that will spoil while waiting for cooking to start, such as dishes with milk or eggs, cream soups, and cooked meats or fish. Any food that has to wait for cooking to start should be very cold or frozen before it is put in the oven. **MOST UNFROZEN FOODS SHOULD NEVER STAND MORE THAN TWO HOURS BEFORE COOKING STARTS.**
- Do not use foods containing baking powder or yeast when using delay start. They will not rise properly.
- Do not allow food to remain in oven for more than two hours after end of cooking cycle.

*Tmk

Using Your Lower Oven Continued

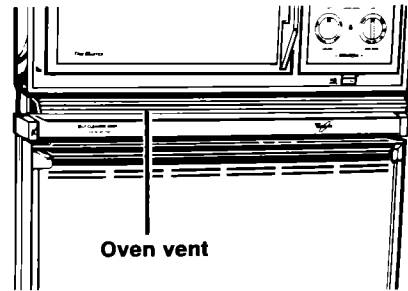

The oven vent

Hot air and moisture escape from the lower oven through a vent just above the lower oven door.

Do not block the vent. Poor baking can result.

Optional rotisserie

If you would like a rotisserie for your lower oven, you can order a kit (Part No. 261881) from your Whirlpool Dealer. The kit includes easy installation instructions.

Door panel replacement

If you need to replace your lower oven door glass, you can order White Panel Kit No. 814069 from your Whirlpool Dealer. This kit includes easy installation instructions.

Caring For Your Lower Oven

⚠ WARNING

Burn or Electrical Shock Hazard
Make sure all controls are OFF and the lower oven is COOL before cleaning. Failure to do so can result in burns or electrical shock.

USING YOUR LOWER OVEN • CARING FOR YOUR LOWER OVEN

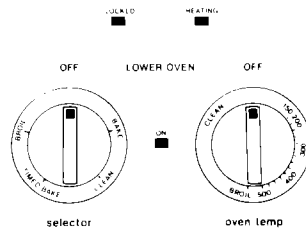
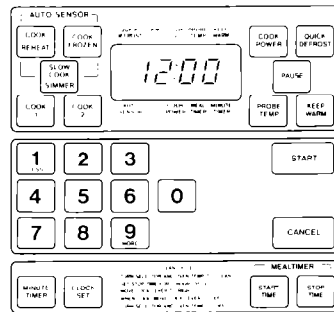

Control panel and knobs

1. Pull control knobs straight off.
2. Use warm soapy water and a soft cloth, or spray glass cleaner, to wipe the control panel. Rinse and wipe dry.
3. Wash control knobs in warm soapy water. Rinse well and dry. Do not soak.
4. Push control knobs straight back on. Make sure they point to OFF.

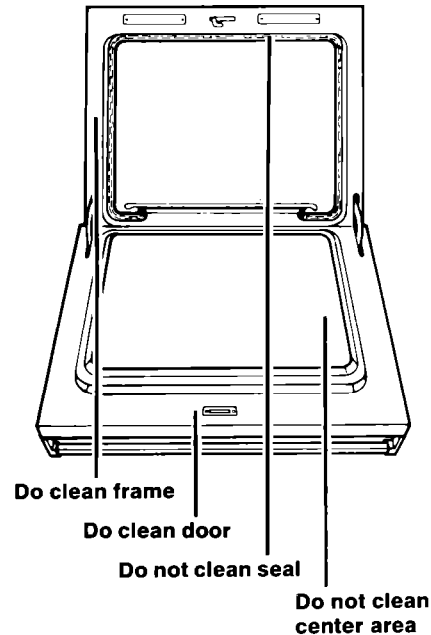

Using the Self-Cleaning cycle

The Self-Cleaning cycle uses **very high heat** to burn away soil. Before you start, make sure you understand exactly how to use the Self-Cleaning cycle safely.

Before you start

1. Clean the areas shown by hand.

They do not get hot enough during the Self-Cleaning cycle for soil to burn away. Use hot water and detergent or a soapy steel wool pad on...

- The inside of the door. (The center area of the door does not need to be hand cleaned.)
- The frame around the oven.

Do not clean the fiberglass seal.

Do not move it or bend it. Poor cleaning and poor baking will result.

2. Remove the broiler pan and any pots and pans you may have stored in the oven. They can't stand the heat.

3. Wipe out any loose soil or grease. This will help reduce smoke during the Self-Cleaning cycle.

4. If the oven has a rotisserie, make sure the motor socket cover is closed.

5. If you want the oven racks to remain shiny, remove from the oven and clean by hand. Otherwise, put oven racks on second and fourth guides (guides are counted from bottom to top). After racks are cleaned in the Self-Cleaning cycle, they become harder to slide. See page 19.

Turn on a vent hood or other kitchen vent during the Self-Cleaning cycle. This will help remove heat and odors that are normal during the cycle.

⚠ WARNING

Personal Injury and Product Damage Hazard

- Do not touch the oven during the Self-Cleaning cycle. It could burn you.
- Do not use commercial oven cleaners in your oven. Cleaners may produce hazardous fumes or damage the porcelain finish.
- Do not force the Lock Lever, you could bend or break it. The lever is designed to stay locked until the oven is cool enough to safely open. Wait until it moves freely.
- Do not use foil or other liners in the oven. During the Self-Cleaning cycle foil can burn or melt and damage the oven surface.
- Do not block the vent during the Self-Cleaning cycle. Air must move freely for best cleaning results.
- Do not leave plastic utensils near the vent. They may melt.

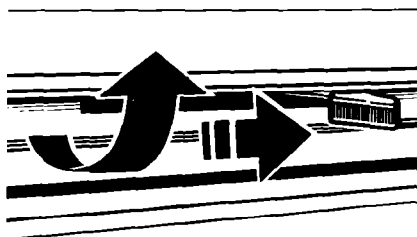
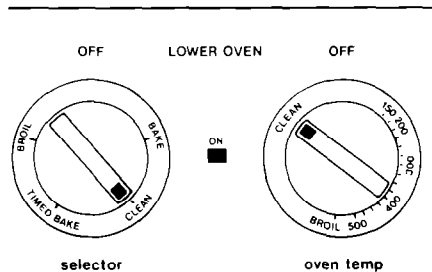

Setting the controls

1. Set the Oven Selector and Oven Temperature Control on CLEAN. The lower oven ON signal light will come on.
2. Lift the panel between the upper and lower oven doors. Move the Lock Lever **all the way to the right** – the Clean position.

Caring For Your Lower Oven Continued

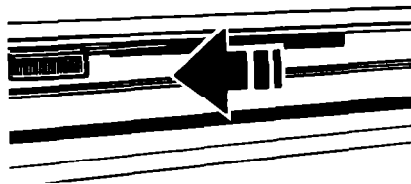
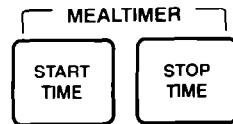
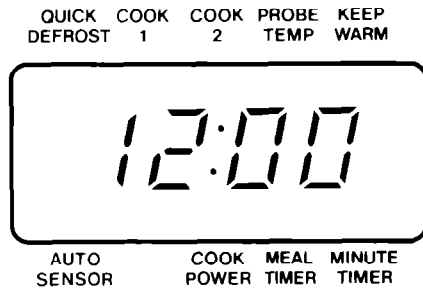

3. Make sure the clock is set to the right time of day. (See Upper Microwave Oven Use and Care Guide for instructions.)
4. Set a 2 to 4 hour Self-Cleaning cycle. Touch Stop Time pad, then touch the number pads for the time you want to stop. A 3-hour Self-Cleaning cycle is recommended for moderately soiled ovens.
 - Use 2 hours for light soil.
 - Use 3-4 hours for moderate to heavy soil.

(Option) Delayed clean: Touch the Start Time pad, then touch the number pads for the time you want to start. Make sure Start Time is 2-4 hours before Stop Time.
5. Touch START. The oven will start the Self-Cleaning cycle automatically at the time you have set. The lower oven Locked signal light will come on when the oven temperature exceeds normal baking temperatures. The Lock Lever must not be moved and the door can't be opened when this light is on.
6. After the Self-Cleaning cycle is completed, the Lower Oven Locked signal light goes off. Move the Lock Lever back to the left. **Do not force it.** Wait until it will move easily.

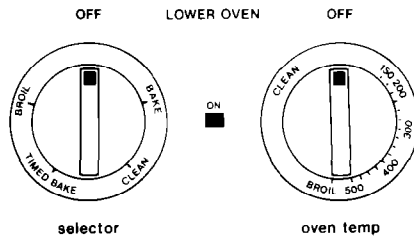

7. Turn the Oven Selector and Oven Temperature Control to OFF. The lower oven ON signal light will go off.

8. **After the oven is cool**, wipe off any residue or ash with a damp cloth. If needed, touch up spots with a soapy steel wool pad.

Special tips

- Keep the kitchen well ventilated during the Self-Cleaning cycle to help get rid of normal heat, odors and smoke.
- Clean the oven before it gets heavily soiled. Cleaning a very soiled oven takes longer and results in more smoke than usual.
- If the Self-Cleaning cycle doesn't get the oven as clean as you expected, the cycle may not have been set long enough or you may not have prepared the oven properly. Set the Self-Cleaning cycle longer the next time and hand clean areas noted on page 14.

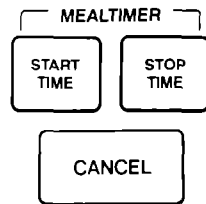

To stop the Self-Cleaning cycle at any time.

1. Touch STOP TIME.
2. Touch CANCEL.

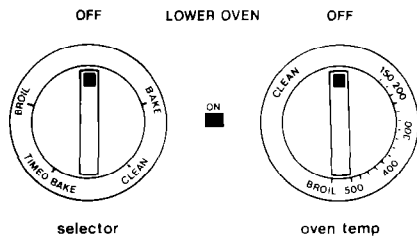

3. When the lower oven Locked signal light goes off, move the Lock Lever back to the left. **Do not force it.** Wait until it moves easily.

Caring For Your Lower Oven Continued

How it works

During the Self-Cleaning cycle, the oven gets much hotter than it does for baking or broiling...approximately 875°F (468°C). This heat breaks up grease and soil and burns it off.

This graph shows approximate temperatures and times during a Self-Cleaning cycle for 3 hours.

Self-Cleaning cycle – three hour setting

(Approximate temperatures and times)

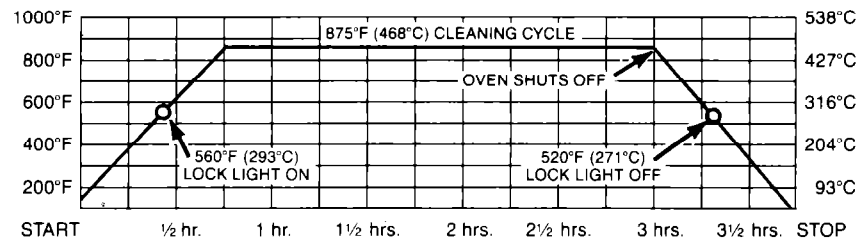

Notice that the heating stops when the 3-hour setting is up, but that it takes longer for the oven to cool down enough to unlock.

Cleaning tips

Control knobs

Clean with warm soapy water and a soft cloth.

- Wash, rinse and dry well.
- Do not soak.

Control panel

Clean with warm soapy water or spray glass cleaner and a soft cloth.

- Wash, rinse and dry well.
- Follow directions provided with the cleaner.

Lower oven exterior

Clean with warm soapy water and a soft cloth.

- Wipe off regularly when lower oven is cool.

Use a plastic scrubbing pad for stubborn spots.

- Do not use abrasive or harsh cleaners.

NOTE: Do not allow food containing acids (such as vinegar, tomato, lemon juice or milk) to remain on surface. Acids will remove the glossy finish.

Broiler pan and grid

Clean with warm soapy water or a steel wool pad.

- Clean after each use.
- Wash, rinse and dry well.
- Do not clean in Self-Cleaning Oven.

Oven racks

Use Self-Cleaning cycle.

- Leave in oven during Self-Cleaning cycle.

OR

Clean with warm soapy water or soapy steel wool pads.

- Wash, rinse and dry. Use soapy steel wool pads for stubborn areas.

NOTE: The oven racks will discolor and be harder to slide when left in the Self-Cleaning cycle. If you want them to stay shiny, remove from the oven and clean by hand.

Lower oven door glass

Use spray glass cleaner or warm soapy water and a plastic scrubbing pad.

- Make sure oven is cool.
- Follow directions provided with the cleaner.
- Wash, rinse and dry well.

Self-Cleaning lower oven

For areas outside the Self-Cleaning area use warm soapy water or soapy steel wool pads.

- Follow directions starting on page 14, "Using the Self-Cleaning cycle."
- Do not use commercial oven cleaners.
- Do not use foil to line the bottom of your Self-Cleaning Oven.

The lower oven light

The lower oven light will come on when you open the lower oven door. To turn the light on when the lower oven door is closed, push the right side of the Oven Light Switch below the control panel. Push the left side of the switch to turn off the light.

⚠ WARNING

Electrical Shock and Personal Injury Hazard

- **Make sure oven and light bulb are cool and power to the oven has been turned OFF before replacing the light bulb. Failure to do so could result in electrical shock or burns.**
- **The bulb cover must be in place when using the oven. The cover protects the bulb from breaking, and from high oven temperatures. Broken glass could cause injury.**

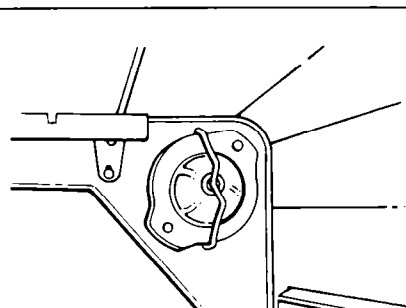
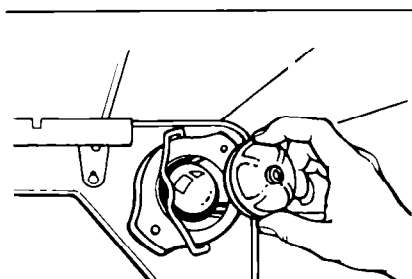

To replace the oven light:

1. Turn the power off at the main power supply.
 2. Remove the bulb cover in the back of the oven by pulling out and pushing the wire holder to the side.
 3. Remove the light bulb from its socket. Replace the bulb with a 40-watt appliance bulb.
 4. Replace the bulb cover and snap the wire holder in place. Turn the power back on at the main power supply.
- NOTE:** The oven light will not work during the Self-Cleaning cycle.

If You Need Service Or Assistance...

We suggest you follow these five steps:

1. Before calling for assistance...

Performance problems often result from little things you can find and fix without tools of any kind.

If nothing operates:

- Is the power supply cord plugged into a live circuit with the proper voltage? (See Installation Instructions.)
- Have you checked your home's main fuses or circuit breaker box?

If the lower oven will not operate:

- Is the Oven Selector turned to a setting (BAKE or BROIL, but not TIMED BAKE)?
- Is the Oven Temperature Control turned to a temperature setting?

If the Self-Cleaning cycle will not operate:

- Are the Oven Selector and Oven Temperature Control set on CLEAN?
- Does the clock show the right time of day?
- Is Stop Time set ahead to the time you want the Self-Cleaning cycle to stop?
- Is the Lock Lever all the way to the right?

If cooking results aren't what you expected:

- Is the oven level?
- Does the oven temperature seem too low or too high? See page 7.
- If needed, have you preheated the oven as the recipe calls for?
- Are you following a tested recipe from a reliable source?
- Are you using pans recommended in the Cooking Guide?
- If baking, have you allowed 1½ to 2 inches (4-5 cm) on all sides of the pans for air circulation?
- Are the pans the size called for in the recipe?
- Do the cooking utensils have smooth, flat bottoms and fit the surface elements being used?

If You Need Service Or Assistance Continued

2. If you need assistance*..

Call Whirlpool COOL-LINE® service assistance telephone number. Dial free from anywhere in the U.S.: 1-800-253-1301

and talk with one of our trained consultants. The consultants can instruct you in how to obtain satisfactory operation from your appliance or, if service is necessary, recommend a qualified service company in your area.

3. If you need service*..



Whirlpool has a nationwide network of franchised TECH-CARE® Service Companies. TECH-

CARE service technicians are trained to fulfill the product warranty and provide after-warranty service, anywhere in the United States. To locate TECH-CARE service in your area, call our COOL-LINE service assistance telephone number (see Step 2) or look in your telephone directory Yellow Pages under:

APPLIANCES - HOUSEHOLD -
MAJOR - SERVICE & REPAIR

ELECTRICAL APPLIANCES -
MAJOR - REPAIRING & PARTS

OR

WASHING MACHINES, DRYERS
& IRONERS - SERVICING

WHIRLPOOL APPLIANCES
FRANCHISED TECH-CARE SERVICE

SERVICE COMPANIES

XYZ SERVICE CO
123 MAPLE

999-9999

4. If you have a problem*..

Call our COOL-LINE service assistance telephone number (see Step 2) and talk with one of our consultants, or if you prefer, write:

Mr. Donald Skinner
Director of Customer Relations
Whirlpool Corporation
2000 M-63
Benton Harbor, MI 49022

Please include a daytime phone number in your correspondence.

5. If you need FSP® replacement parts*..

FSP is a registered trademark of Whirlpool Corporation for quality parts. Look for this symbol of quality whenever you need a replacement part for your Whirlpool appliance. FSP replacement parts will fit right and work right, because they are made to the same exacting specifications used to build every new Whirlpool appliance.

To locate FSP replacement parts in your area, refer to Step 3 above or call the Whirlpool COOL-LINE service assistance number in Step 2.

*If you must call or write, please provide: model number, serial number, date of purchase, and a complete description of the problem. This information is needed in order to better respond to your request for assistance.

Whirlpool® Microwave Oven/Range Product Warranty

ME001

LENGTH OF WARRANTY	WHIRLPOOL WILL PAY FOR
FULL ONE-YEAR WARRANTY From Date of Purchase	FSP® replacement parts and repair labor to correct defects in materials or workmanship. Service must be provided by a franchised TECH-CARE® service company.
LIMITED FOUR-YEAR WARRANTY Second Through Fifth Year From Date of Purchase	FSP® replacement magnetron tube on microwave ovens if defective in materials or workmanship.
WHIRLPOOL WILL NOT PAY FOR	
<p>A. Service calls to:</p> <ol style="list-style-type: none"> 1. Correct the installation of the range product. 2. Instruct you how to use the range product. 3. Replace house fuses or correct house wiring or plumbing. 4. Replace owner accessible light bulbs. <p>B. Repairs when range product is used in other than normal, single-family household use.</p> <p>C. Pick up and delivery. This product is designed to be repaired in the home.</p> <p>D. Damage to range product caused by accident, misuse, fire, flood, acts of God or use of products not approved by Whirlpool.</p> <p>E. Any labor costs during the limited warranty.</p>	

WHIRLPOOL CORPORATION SHALL NOT BE LIABLE FOR INCIDENTAL OR CONSEQUENTIAL DAMAGES. Some states do not allow the exclusion or limitation of incidental or consequential damages so this limitation or exclusion may not apply to you. This warranty gives you specific legal rights, and you may also have other rights which vary from state to state.

Outside the United States, a different warranty may apply. For details, please contact your franchised Whirlpool distributor or military exchange.

